

SIGSAUER®



CLASSIC LINE PISTOLS®

OPERATOR'S MANUAL: HANDLING & SAFETY INSTRUCTIONS

READ THE INSTRUCTIONS AND WARNINGS IN THIS MANUAL CAREFULLY BEFORE USING THIS FIREARM.

DO NOT DISCARD THIS MANUAL.

THIS MANUAL SHOULD ALWAYS ACCOMPANY THIS FIREARM AND BE TRANSFERRED WITH IT UPON CHANGE IN OWNERSHIP, OR WHEN THE FIREARM IS PRESENTED TO ANOTHER PERSON.





WARNINGS

1.0 SAFETY WARNINGS

READ THIS ENTIRE MANUAL THOROUGHLY AND CAREFULLY PRIOR TO USING THIS FIREARM.

The warnings in this operators manual are extremely important. By understanding the dangers inherent in the use of any firearm, and by taking the precautions described in this manual, you can experience a high level of safety in the use of your firearm. Failure to heed any of these warnings may result in serious injury or death to you or others, as well as severe damage to the firearm or other property.

WARNINGS in this manual identify a clear danger to the person performing that procedure. Warnings are identified by a red banner with the word **WARNING** in white, bold, uppercase letters and a **WARNING** icon. Failure to comply with a **WARNING** can result in serious injury or death to you or a bystander.



WARNING

CAUTIONS in this manual identify a risk of damage to the firearm being maintained. **CAUTIONS** are identified by a black banner with the word **CAUTION** in white, bold uppercase letters.

CAUTION

NOTES in this manual identify essential information to the individual performing the procedure. **NOTES** are identified by a white banner with the word **NOTE** in black, bold uppercase letters.

NOTE



WARNINGS

SIG SAUER

As a valued SIG SAUER customer, we encourage you to visit sigsauer.com. There you will find links to product information and updates, merchandise promotions, and educational videos that will be of interest to you as an owner of SIG SAUER products.

SIG SAUER firearms are designed to function reliably with proper care and knowledgeable use. You must understand the safe operation and use of your SIG SAUER firearm. Read and follow these instructions carefully. Do not use the firearm unless you fully understand these instructions and the safe operation of your firearm. Failure to heed any of these instructions may result in serious injury or death to you or others, as well as severe damage to the firearm or other property.

Your firearm comes equipped with effective, well-designed safety features. However, never rely completely on any safety mechanism. Safety mechanisms are designed to augment, not replace safe handling practices. Careless and improper handling of any firearm can result in an unintentional discharge.

Only your safe firearm handling habits will ensure the safe use of your firearm. Like all mechanical devices, the safety mechanisms are subject to breakage or malfunction and can be negatively affected by wear, abuse, dirt, corrosion, incorrect assembly, improper adjustment or repair, or lack of maintenance. Moreover, there is no such thing as a safety mechanism that is “childproof” or that can completely prevent accidental discharge from improper usage, “horseplay”, or abusive handling.

The best safety is proper and applied training in safe firearm handling. Always handle your firearm as though you expect the safeties not to work.



WARNINGS

1.0 SAFETY WARNINGS (CONTINUED)

Do not load a round into the chamber until you are ready to use the pistol. If your firearm is equipped with a manual safety, keep the safety ON until you are ready to fire. Always move the safety to its intended position and visually check it. The safety is not ON unless it is completely ON.

ABUSIVE HANDLING

SIG SAUER firearms incorporate effective mechanical safeties. However, like any mechanical device, exposure to abusive conditions may have a negative effect on these safety mechanisms and cause them to fail to work as designed. Do not subject your SIG SAUER firearm to any type of abusive handling. This includes the firearm being dropped, impact to the firearm, or the firearm being struck by another object. Make sure you always maintain control of your firearm at all times. If your firearm does suffer an abusive event such as previously described, do not attempt to use the firearm. Keep the firearm pointed in a safe direction, unload and clear the firearm of all ammunition immediately, and have it inspected by a certified SIG SAUER armorer or gunsmith prior to using the firearm.

A safe direction is defined as an area in which, if the firearm were to discharge, no property damage would occur and no personal injury would result.

As previously noted, if your SIG SAUER firearm does suffer an abusive event, unload it immediately and have it inspected by a certified SIG SAUER Armorer or gunsmith prior to using the firearm. If your firearm suffers an abusive event during a life-threatening/self-defense situation, you must apply immediate action by;

1. Pulling the slide completely rearward to eject the chambered cartridge.
2. Releasing the slide to chamber a new cartridge and resetting the trigger mechanism. (Do not ride the slide forward)
3. The firearm is now returned to proper operational condition.



WARNINGS

SIG SAUER

Intentional or repetitive abusive handling of any SIG SAUER firearm will void the manufacturer's warranty and could render the firearm unsafe.



WARNING

SAFETY



THE MANUAL SAFETY MUST BE ENGAGED ON SAO MODEL PISTOLS WHEN THE PISTOL IS LOADED AND A LIVE CARTRIDGE IS CHAMBERED.

REPLACEMENT PARTS

Do not attempt to disassemble your SIG SAUER firearm beyond the point explained in this manual. Disassembly beyond the instructions in this manual is restricted to a certified SIG SAUER armorer or professional gunsmith. Failure to comply with these restrictions will void your warranty.

Warnings and instructions about the use of some SIG SAUER replacement parts, assemblies, and accessories may be described in literature accompanying the specific products. Read and carefully follow those instructions. Such warnings and instructions are provided to assure the safe functioning of the firearm. Failure to heed them may result in improper functioning, damage to the firearm, and serious injury or death.

ALTERATIONS

This SIG SAUER firearm was designed to function properly in its original condition. Unauthorized alterations can make it unsafe. Do not alter any part or add or substitute any parts or accessories not manufactured by SIG SAUER for this pistol. The addition of any parts or accessories beyond the user level of maintenance described in this manual are not authorized.



WARNINGS

1.0 SAFETY WARNINGS (CONTINUED)

ACCESSORIES

It is your responsibility to ensure that all accessories, such as holsters and firearm-mounted lights, are compatible with this firearm and that the accessories do not interfere with the safe operation and handling of the firearm. If you are lawfully carrying the firearm concealed, you must ensure that the holster you choose is made for your particular firearm and designed for the type of carry in which you intend to engage.

TRANSPORTING

When transporting your firearm, be sure the firearm is unloaded and cleared of all ammunition. It is your responsibility to familiarize yourself with the laws of any state you will be traveling through with your firearm.

STORAGE

The only safe way to store your firearm is unloaded, cleared of all ammunition, and secure. Safe and secure storage is one of your most important responsibilities. Store your unloaded firearm separate from your ammunition and in places inaccessible to children or unauthorized persons.

CHAMBER SAFETY FLAG

Every SIG SAUER firearm is shipped with a chamber safety flag. The chamber safety flag prevents the chambering of a round when installed and provides a readily visible indication that the firearm's chamber is empty. The chamber safety flag is to be installed in the firearm's chamber at all times when the firearm is not in use. Many public ranges require chamber safety flags be installed when the firing line is cold.



WARNINGS

SIG SAUER

LIABILITY

PISTOLS are classified as FIREARMS and are sold by SIG SAUER with the specific understanding that we shall not be responsible in any manner whatsoever for malfunctioning of the firearm, physical injury, or property damage resulting in whole or in part from:

- Criminal or negligent discharge
- Improper, careless, or abusive handling
- Unauthorized modifications or parts replacement
- Defective, improper, hand-loaded, or reloaded ammunition
- Corrosion
- Neglect
- Other influences beyond our direct and immediate control

This limitation applies regardless of whether liability is asserted on the basis of contract, negligence, or strict liability (including any failure to warn). Under no circumstance shall SIG SAUER, Inc. be liable for incidental or consequential damages, such as loss of use of property, commercial loss, and loss of earnings or profits.



WARNINGS

1.0 SAFETY WARNINGS (CONTINUED)

BASIC RULES OF SAFE FIREARMS HANDLING

1. ALWAYS treat every firearm as if it were loaded.
2. ALWAYS be sure that the barrel is clear of any obstruction.
3. ALWAYS be sure of your backstop, what lies beyond, and the safety of bystanders before you shoot.
4. ALWAYS use clean, dry, original factory-made ammunition of the proper type and caliber for your firearm.
5. ALWAYS wear ear protection and safety glasses when shooting.
6. ALWAYS carry your firearm so that you can control the direction of the muzzle if you fall or stumble.
7. NEVER shoot at a flat surface or water.
8. DO NOT leave an unattended firearm loaded. Firearms and ammunition should be stored separately, locked if possible, beyond the reach of children, careless adults, and unauthorized users.
9. NEVER allow your firearm to be used by anyone who has not read and understood this operator's manual.
10. DO NOT point any firearm, loaded or unloaded, at any undesired target.
11. NEVER discharge your firearm near an animal unless the animal is trained to accept the noise. An animal's startled reaction could injure it or cause an accident.
12. NEVER drink alcoholic beverages or use drugs before or during shooting, as your vision and judgment could be seriously impaired, making your firearm handling unsafe.



WARNINGS

SIG SAUER

1.1 EYE AND EAR PROTECTION



Always wear safety glasses that meet the requirements of American National Standards Institute (ANSI) z87.1 and ear plugs and “ earmuff ”-type protectors whenever you are shooting. Always make certain that persons close to you are similarly protected. Unprotected eyes may be injured by powder, gas, carbon residue, lubricant, metallic particles, or similar debris that may emanate occasionally from any firearm in normal use. Without ear protection, repeated exposure to shooting noise may lead to cumulative, permanent hearing loss.

1.2 AMMUNITION

Use only high-quality, original, factory-manufactured ammunition. Do not use cartridges that are dirty, wet, corroded, bent, or damaged. Do not oil cartridges. Do not spray aerosol-type lubricants, preservative, or cleaners directly onto cartridges or where excess spray may flow into contact with cartridges. Lubricant or other foreign matter on cartridges can cause potentially dangerous ammunition malfunctions. Use only ammunition of the caliber for which your firearm is chambered. The proper caliber is permanently engraved on your firearm; never attempt to use ammunition of any other caliber.

The use of reloaded, “re-manufactured” hand loaded, or other nonstandard ammunition voids all warranties. Reloading is a science and improperly loaded ammunition can be extremely dangerous.



WARNINGS

1.2 AMMUNITION (CONTINUED)

Severe damage to the firearm and serious injury to the shooter or to others may result. Always use ammunition that complies with the industry performance standards established by the Sporting Arms and Ammunition Manufacturers' Institute, Inc. of the United States (SAAMI) or ammunition manufactured to military specifications.

SIG SAUER Inc. Specifically disclaims responsibility for any damage or injury whatsoever occurring in connection with, or as a result of, the use in any SIG SAUER firearm of faulty, nonstandard, "re-manufactured" hand-loaded (reloaded) ammunition, or cartridges other than those for which the firearm was originally chambered.

Firearms may be severely damaged and serious injury to the shooter or to others may result from any condition causing excessive pressure inside the chamber or barrel during firing. Excessive pressure can be caused by obstructions in the barrel, propellant powder overloads, the use of incorrect cartridges, or defectively assembled cartridges. In addition, the use of a dirty, corroded, or damaged cartridge can lead to a burst cartridge case and consequent damage to the firearm and personal injury from the sudden escape of high-pressure propellant gas within the firearm's mechanism.

OBSTRUCTED BORE

Immediately stop shooting and check the barrel for a possible obstruction whenever:

- You have difficulty in, or feel unusual resistance in, chambering a cartridge;
- A cartridge misfires (does not go off);
- The mechanism fails to extract a fired cartridge case;
- Unburned grains of propellant powder are discovered spilled in the mechanism;
- A shot sounds weak or abnormal. It is possible that a bullet is lodged part way down the barrel.



WARNINGS

SIG SAUER

- Firing a subsequent bullet into the obstructed barrel can damage the firearm and cause serious injury to the shooter or to bystanders.

Bullets can become lodged in the barrel:

- If the cartridge has been improperly loaded without propellant powder, or if the powder fails to ignite (ignition of the cartridge primer alone will push the bullet out of the cartridge case, but usually does not generate sufficient energy to expel the bullet completely from the barrel);
- If the bullet is not properly seated in the cartridge case. When such a cartridge is extracted from the chamber without being fired, the bullet may be left behind in the bore at the point where the rifling begins. Subsequent chambering of another cartridge may push the first bullet further into the bore.

If there is any reason to suspect that a bullet is obstructing the barrel, immediately unload and clear the firearm. Field strip the pistol and look through the bore of the barrel. It is not sufficient to merely look in the chamber. A bullet may be lodged some distance down the barrel where it cannot easily be seen.

If a bullet is in the bore, do not attempt to shoot it out by using another cartridge or by blowing it out with a blank or a cartridge from which the bullet has been removed. Such techniques can generate excessive pressure, damage the firearm, and cause serious personal injury or death.

If the bullet can be removed by using a cleaning rod, clean any unburned powder grains from the bore, chamber, and fire control assembly before resuming shooting. If the bullet cannot be dislodged by tapping it with a cleaning rod, take the firearm to a gunsmith or certified SIG SAUER armorer.



WARNINGS

1.2 AMMUNITION (CONTINUED)

Dirt, corrosion, or other foreign matter on a cartridge can impede complete chambering and may cause the cartridge case to burst upon firing. A damaged or deformed cartridge may also impede chambering performance and cause the cartridge case to burst upon firing.

Do not lubricate cartridges, and be sure to wipe the chamber clean of any oil or preservative before shooting. Oil interferes with the friction between cartridge case and chamber wall that is necessary for safe functioning, and subjects the firearm to stress similar to that imposed by excessive pressure.

Use lubricants sparingly on the moving parts of your firearm. Avoid excessive spraying of any aerosol gun care product, especially where it might get on ammunition. All lubricants and aerosol spray lubricants in particular can penetrate cartridge primers and cause misfires. Some highly penetrative lubricants can also migrate inside cartridge cases and cause deterioration of the propellant powder; on firing, the powder might not ignite. If only the primer ignites, there is danger that the bullet may become lodged in the barrel.

Death, serious injury, and damage can result from the use of wrong ammunition, bore obstructions, powder overloads, or incorrect cartridge components. Always wear shooting glasses and hearing protectors. Improper ammunition destroys firearms.



WARNINGS

SIG SAUER



WARNING: CANCER AND REPRODUCTIVE HARM—www.P65warnings.ca.gov



DISCHARGING FIREARMS IN POORLY VENTILATED AREAS, CLEANING FIREARMS, OR HANDLING AMMUNITION MAY RESULT IN EXPOSURE TO LEAD AND OTHER SUBSTANCES KNOWN TO THE STATE OF CALIFORNIA TO CAUSE BIRTH DEFECTS, REPRODUCTIVE HARM, AND OTHER SERIOUS PHYSICAL INJURY. MAINTAIN ADEQUATE VENTILATION AT ALL TIMES. WASH HANDS THOROUGHLY AFTER EXPOSURE. SHOOTING OR CLEANING FIREARMS MAY EXPOSE YOU TO LEAD.



WARNINGS

1.3 STATE-BY-STATE WARNINGS

Certain states require, by law, that their own specified warning notices, in larger-than-normal type be conspicuously included by the manufacturer, distributor, or retail dealer with firearms sold in that state. SIG SAUER sells its products in compliance with applicable laws and regulations. Because our products may be sold in these states, we include the following:



CALIFORNIA: WARNING

Firearms must be handled responsibly and securely stored to prevent access by children and other unauthorized users. California has strict laws pertaining to firearms, and you may be fined or imprisoned if you fail to comply with them. Visit the Web site of the California Attorney General at <https://oag.ca.gov/firearms> for information on firearm laws applicable to you and how you can comply. Prevent child access by always keeping guns locked away and unloaded when not in use. If you keep a loaded firearm where a child obtains and improperly uses it, you may be fined or sent to prison.”

If you or someone you know is contemplating suicide, please call the National Suicide Prevention Lifeline at 1-800-273 TALK (8255).



ADVERTENCIA

Las armas de fuego deben manipularse de manera responsable y segura para evitar el acceso de niños y otros usuarios no autorizados. California tiene leyes estrictas relacionadas con armas de fuego, y usted puede ser multado o encarcelado si no las cumple. Visite el sitio web del fiscal general de California en <https://oag.ca.gov/firearms> para obtener información sobre las leyes de armas de fuego que son aplicables y cómo puede cumplirlas. Evite el acceso de niños manteniendo siempre las armas bloqueadas y descargadas cuando no estén en uso. Si mantiene un arma de fuego cargada donde un niño la puede obtener y la usa indebidamente, se le puede multar o enviar a prisión.

Si usted o alguien que conoce está contemplando el suicidio, llame a la Línea Nacional de Prevención del Suicidio al 1-800-273 TALK (8255).



WARNINGS

SIG SAUER

CONNECTICUT:

“UNLAWFUL STORAGE OF A LOADED FIREARM MAY RESULT IN IMPRISONMENT OR FINE.”

FLORIDA:

“IT IS UNLAWFUL, AND PUNISHABLE BY IMPRISONMENT AND FINE, FOR ANY ADULT TO STORE OR LEAVE A FIREARM IN ANY PLACE WITHIN THE REACH OR EASY ACCESS OF A MINOR UNDER 18 YEARS OF AGE OR TO KNOWINGLY SELL OR OTHERWISE TRANSFER OWNERSHIP OR POSSESSION OF A FIREARM TO A MINOR OR A PERSON OF UNSOUND MIND.”

MAINE:

“ENDANGERING THE WELFARE OF A CHILD IS A CRIME. IF YOU LEAVE A FIREARM AND AMMUNITION WITHIN EASY ACCESS OF A CHILD, YOU MAY BE SUBJECT TO FINE, IMPRISONMENT OR BOTH. KEEP FIREARMS AND AMMUNITION SEPARATE. KEEP FIREARMS AND AMMUNITION LOCKED UP. USE TRIGGER LOCKS.”

MARYLAND:

“WARNING: Children can operate firearms which may cause death or serious injury. It is a crime to store or leave a loaded firearm in any location where an individual knew or should have known that an unsupervised minor would gain access to the firearm. Store your firearm responsibly!”



WARNINGS

MASSACHUSETTS:

“WARNING FROM THE MASSACHUSETTS ATTORNEY GENERAL:

This handgun is not equipped with a device that fully blocks use by unauthorized users. More than 200,000 firearms like this one are stolen from their owners every year in the United States. In addition, there are more than a thousand suicides each year by younger children and teenagers who get access to firearms. Hundreds more die from accidental discharge. It is likely that many more children sustain serious wounds, or inflict such wounds accidentally on others. In order to limit the chance of such misuse, it is imperative that you keep this weapon locked in a secure place and take other steps necessary to limit the possibility of theft or accident. Failure to take reasonable preventative steps may result in innocent lives being lost, and in some circumstances may result in your liability for these deaths.”

“IT IS UNLAWFUL TO STORE OR KEEP A FIREARM, RIFLE, SHOTGUN OR MACHINE GUN IN ANY PLACE UNLESS THAT WEAPON IS EQUIPPED WITH A TAMPER RESISTANT SAFETY DEVICE OR IS STORED OR KEPT IN A SECURELY LOCKED CONTAINER.”



WARNINGS

SIGSAUER

NEW JERSEY:

“IT IS A CRIMINAL OFFENSE TO LEAVE A LOADED FIREARM WITHIN EASY ACCESS OF A MINOR.”

NEW YORK CITY, NY:

“THE USE OF A LOCKING DEVICE OR SAFETY LOCK IS ONLY ONE ASPECT OF RESPONSIBLE WEAPON STORAGE. ALL WEAPONS SHOULD BE STORED UNLOADED AND LOCKED IN A LOCATION THAT IS BOTH SEPARATE FROM THEIR AMMUNITION AND INACCESSIBLE TO CHILDREN AND ANY OTHER UNAUTHORIZED PERSONS. NEW YORK CITY LAW PROHIBITS, WITH CERTAIN EXCEPTIONS, ANY PERSON FROM ACQUIRING MORE THAN ONE FIREARM, OR MORE THAN ONE RIFLE OR SHOTGUN, WITHIN A 90-DAY PERIOD.”

NORTH CAROLINA:

Any person who resides in the same premises as a minor, owns or possesses a firearm, and stores or leaves the firearm (i) in a condition that the firearm can be discharged and (ii) in a manner that the person knew or should have known that an unsupervised minor would be able to gain access to the firearm, is guilty of a Class 1 misdemeanor if a minor gains access to the firearm without the lawful permission of the minor's parents or a person having charge of the minor and the minor:

- (1) Possesses it in violation of G.S. 14-269.2(b)
- (2) Exhibits it in a public place in a careless, angry, or threatening manner;
- (3) Causes personal injury or death with it not in self defense; or
- (4) Uses it in the commission of a crime.



WARNINGS

TEXAS:

“IT IS UNLAWFUL TO STORE, TRANSPORT, OR ABANDON AN UNSECURED FIREARM IN A PLACE WHERE CHILDREN ARE LIKELY TO BE AND CAN OBTAIN ACCESS TO THE FIREARM.”

WISCONSIN:

“IF YOU LEAVE A LOADED FIREARM WITHIN THE REACH OR EASY ACCESS OF A CHILD YOU MAY BE FINED OR IMPRISONED OR BOTH IF THE CHILD IMPROPERLY DISCHARGES, POSSESSES, OR EXHIBITS THE FIREARM.”

Please check with your licensed retailer, state police, or local police for additional warnings, which may be required by local law or regulation. Such regulations change constantly, and local authorities are in the best position to advise you on such legal matters.



WARNINGS

SIG SAUER

1.4 LOCKING DEVICES



All firearms are originally shipped with a key-operated locking device, except for Custom Works firearms that are shipped with a lockable case.

Although it can help provide secure storage for your unloaded firearm, any locking device can fail.

All firearms are designed to fire if they are loaded and the trigger is pressed. Therefore, never install the locking device inside the trigger guard or in any way that makes it possible to press the trigger! Do not leave the keys in the lock.

The ultimate responsibility for secure storage of any firearm must depend upon its owner and his or her individual circumstances.

Firearms should be stored unloaded, in a secure location, separate from their ammunition.

To maximize effectiveness and reduce the chances of malfunction or damage to a firearm, ALWAYS refer to the locking device's manufacturer directions for installation and removal of the device.



WARNINGS

1.5 SAFETY INFORMATION

FIREARMS SAFETY IS YOUR RESPONSIBILITY

This operator's manual is designed to assist you in learning how to use and care for your SIG SAUER® firearm properly.

Only when you are certain that you fully understand this manual and can properly carry out its instructions, should you practice loading and firing your firearm with live ammunition. Having a firearm in your possession is a full-time job; you cannot guess and you cannot forget. You must know how to use your firearm safely.

If you have any doubts about your ability to handle or use this firearm safely, you should seek supervised instruction.

The SIG SAUER Academy® provides all levels of firearms safety and skill training, from beginner to expert.

For more information contact:

SIG SAUER[®]
ACADEMY

sigsaueracademy.com • (603) 610-3400

Epping, New Hampshire

SAFETY MUST BE THE FIRST AND CONSTANT CONSIDERATION OF EVERY PERSON WHO HANDLES FIREARMS AND AMMUNITION.

For more information about safety, responsible firearms ownership, and shooting sports, contact:

National Rifle Association (NRA) of America
11250 Waples Mill Road, Fairfax, VA 22030-7400 • 1-800-672-3888

www.nra.com

THIS PAGE INTENTIONALLY LEFT BLANK



CONTENTS

Topic	Page
1.0 SAFETY WARNINGS	2
1.1 EYE AND EAR PROTECTION	9
1.2 AMMUNITION	9
1.3 STATE-BY-STATE WARNINGS	14
1.4 LOCKING DEVICES	19
1.5 SAFETY INFORMATION	20
2.0 MECHANICAL CHARACTERISTICS AND THEORY	24
2.1 DESCRIPTION OF FIREARM	24
2.2 MAIN COMPONENTS AND OPERATOR CONTROLS	26
2.3 DAO/DAK SPECIFIC COMPONENTS AND OPERATOR CONTROLS	28
2.4 SAO SPECIFIC COMPONENTS AND OPERATOR CONTROLS	29
3.0 HANDLING	30
3.1 PREPARATION INSTRUCTIONS	30
3.2 SAO MODELS	31
3.3 LOADING THE MAGAZINE	32
3.4 LOADING THE PISTOL READY TO FIRE	33
3.5 RELOADING DURING SHOOTING MAGAZINE DEPLETED	37
3.6 RELOADING DURING SHOOTING PARTIAL MAGAZINE	40
4.0 FIRING	42
4.1 FIRING THE PISTOL	43
5.0 UNLOADING THE PISTOL	46
5.1 UNLOADING THE PISTOL MAGAZINE NOT EMPTY	47
5.2 UNLOADING THE PISTOL MAGAZINE EMPTY, SLIDE OPEN	50
6.0 PROCEDURES IN CASE OF STOPPAGE	52
6.1 TROUBLESHOOTING GUIDE	53
6.2 MINIMIZING STOPPAGES	55
7.0 MAINTENANCE	56
7.1 PISTOL DISASSEMBLY	56
7.2 MAGAZINE DISASSEMBLY	59
7.3 CLEANING THE PISTOL	60

7.4 PISTOL ASSEMBLY	66
7.5 MAGAZINE ASSEMBLY	69
7.6 FUNCTION CHECK	70
8.0 MAGAZINE CATCH REMOVAL AND REVERSAL	75
8.1 MAGAZINE CATCH REMOVAL	76
8.2 MAGAZINE CATCH INSTALLATION	77
9.0 SIGHTS	78
9.1 GENERAL INFORMATION	80
9.2 WINDAGE (LEFT/RIGHT) ADJUSTMENT	81
9.3 ELEVATION (UP/DOWN) ADJUSTMENT	82
10.0 STORAGE AND TRANSPORTATION	83
10.1 STORAGE	83
10.2 TRANSPORTATION	85
11.0 PARTS AND SERVICE POLICY	86
11.1 PARTS POLICY	86
11.2 SERVICE POLICY	87
11.3 SHIPPING FIREARMS FOR REPAIR	88
12.0 STANDARD SLIDE PARTS DIAGRAM	90
12.1 ROMEO 1 SLIDE PARTS DIAGRAM	91
12.2 DA/SA FRAME WITH E2 GRIP	92
12.3 DAO/DAK FRAME WITH TWO PIECE GRIPS	93
12.4 SAO FRAME WITH TWO PIECE GRIP	94
12.5 P229, P226 AND P220 COMPARISON	95
13.0 TECHNICAL SPECIFICATIONS	96
13.1 SPECIFICATIONS BY MODEL	96
APPENDIX A: SRT SUPPLEMENTAL INSTRUCTIONS	97
SIG SAUER® LIMITED LIFETIME FIREARMS WARRANTY	98



2.0 MECHANICAL CHARACTERISTICS AND THEORY

2.1 DESCRIPTION OF FIREARM

2.1.1 GENERAL

The SIG SAUER classic line pistols are modern handguns that incorporate the latest technical advances in firearm design for military, law enforcement, and sporting use. Classic line pistols are mechanically locked, short-recoil-operated pistols with semiautomatic reloading. Firing takes place with each press of the trigger until the magazine is empty. The slide remains open after the last round has been fired from the magazine.

2.1.2 PRINCIPAL FEATURES

The automatic firing pin safety lock ensures safe carrying of the pistol and provides instant readiness without actuating a manual safety.

Distinctive high-contrast sights, in conjunction with the ergonomically correct grip, ensure rapid target acquisition and engagement, even under poor lighting conditions.

Classic line pistols are offered with SIG SAUER Electro Optics.

The Interchangeable grip allows for optimal adaptation of the pistol to the individual user.

The magazine catch can be set up for left or right hand operation.

An accessory rail is integrated into the frame, facilitating the easy attachment of industry standard tactical accessories.

The closed design of the pistol helps keep dirt and other debris from entering the pistol, ensuring proper function in harsh environmental conditions.

Trigger actions are offered in, Double Action/Single Action (DA/SA), Single Action Only (SAO), Double Action Only (DAO) and Double Action Kellerman (DAK).

Manual safeties are ambidextrous and can be operated from either side of the pistol.

SRT (Short Reset Trigger) equipped pistols have a shorter amount of trigger travel before the trigger resets after firing.

Flat, curved, reduced reach and adjustable triggers are available to adapt the pistol to the individual user.

Legion series pistols are equipped with, X-RAY3 high visibility day/night sights, low profile controls and adjustable triggers.



2.2 MAIN COMPONENTS AND OPERATOR CONTROLS

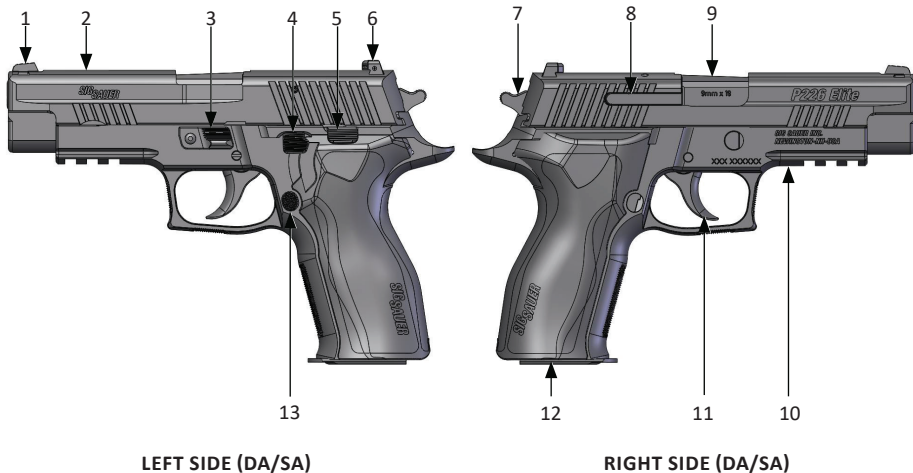

FIGURE 1. OPERATOR CONTROLS AND FEATURES (DA/SA)

TABLE 1. OPERATOR CONTROLS AND FEATURES (DA/SA-DOUBLE ACTION/SINGLE ACTION)

Number	Item Name	Description
1	Front Sight	The means of aiming the pistol.
2	Slide	Houses extractor, firing pin safety lock, firing pin and sights.
3	Take Down Lever	Holds the slide and barrel to the frame.
4	Decocking Lever	Allows the operator to manually release the sear allowing a cocked hammer to reset into the safety intercept notch on a DA/SA pistol without having to press the trigger.
5	Slide Catch Lever	Locks slide to rear upon firing of last cartridge. Can be used to manually lock slide to rear for maintenance.
6	Rear Sight	The means of aiming the pistol.
7	Hammer	Impacts the firing pin, causing it to detonate the primer.
8	Extractor	Pulls spent casings or cartridges out of the chamber of the barrel.
9	Barrel	Houses cartridge for firing and directs projectile.
10	Frame	Supports all major components of pistol.
11	Trigger	When pressed actuates the internal components to cock and/or release the hammer
12	Magazine	Holds and positions cartridges in place for feeding.
13	Magazine Catch	Locks magazine into frame. Releases magazine when pressed. Can be configured for left or right hand user.



2.3 DAO/DAK SPECIFIC COMPONENTS AND OPERATOR CONTROLS

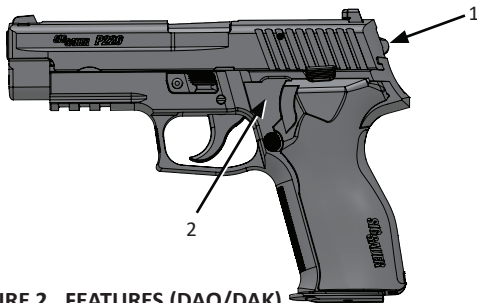

FIGURE 2. FEATURES (DAO/DAK)

TABLE 2. SPECIFIC FEATURES (DAO- DOUBLE ACTION ONLY/DAK- DOUBLE ACTION KELLERMAN)		
Number	Item Name	Description
1	Low Profile Hammer	DAO hammers do not have a traditional spur because, there is no need to manually cock the hammer.
2	No Decocking Lever	The hammer in DAO pistols always returns to a decocked position, so there is no need for a decocking lever.

2.4 SAO SPECIFIC COMPONENTS AND OPERATOR CONTROLS

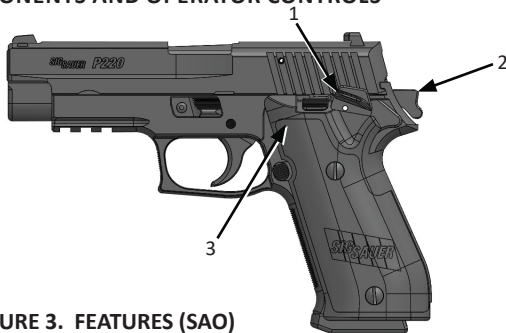

FIGURE 3. FEATURES (SAO)

TABLE 3. UNIQUE FEATURES (SAO- SINGLE ACTION ONLY)		
Number	Item Name	Description
1	Manual Safety Lever	When engaged, prevents the trigger bar from releasing the sear when the hammer is cocked and the trigger is pressed.
2	No Double Action	Pressing the trigger will not cock the hammer.
3	No Decocking Lever	SAO hammers do not have a double action notch. Firing the pistol or manually cycling the slide is the proper method for cocking the hammer.



3.0 HANDLING

3.1 PREPARATION INSTRUCTIONS



WARNING



BEFORE LOADING, ALWAYS CLEAN ALL GREASE AND OIL FROM THE BORE AND CHAMBER, AND VERIFY THAT NO OBSTRUCTION IS IN THE BARREL. ANY FOREIGN MATTER IN THE BARREL COULD RESULT IN A BULGED OR BURST BARREL OR OTHER DAMAGE TO THE FIREARM, AND COULD CAUSE SERIOUS INJURY TO THE SHOOTER OR TO OTHERS.

Prior to firing the pistol for the first time, we strongly suggest that you perform an initial cleaning and lubrication of the pistol after you unpack it. Any fouling present will have been from final range firing at the factory prior to shipping.

Please refer to (section, “7.3 Cleaning the Pistol” on page 60) for instructions pertaining to cleaning the pistol.

If you have the pistol, the correct ammunition, and have read and understood all of the safety instructions, you are now ready to use the pistol.

3.2 SAO MODELS

SIG SAUER classic line SAO pistols are equipped with an ambidextrous manual safety. The manual safety mechanically blocks the movement of the sear, preventing release of the hammer.

To engage the manual safety, rotate the manual safety lever upward. The manual safety is ambidextrous and when one lever is rotated the opposite lever is also rotated. There should be a audible click when engaging or disengaging the manual safety. You can still manipulate the slide with the manual safety engaged. To disengage the manual safety, push down on the manual safety lever and both levers will rotate down to disengage the manual safety.



LEFT SIDE MANUAL SAFETY ENGAGED



RIGHT SIDE MANUAL SAFETY ENGAGED



3.3 LOADING THE MAGAZINE

NOTE

Ensure that the magazine and ammunition is the proper type and caliber for the pistol.

1. Press down on the magazine follower using the cartridge case rim. Ensure that the bullet is facing the front of the magazine.
2. Push the cartridge to the rear and under the magazine lips.
3. Repeat until the magazine holds the desired number of cartridges or it is full. Do not attempt to insert more cartridges than the magazine's designed capacity.

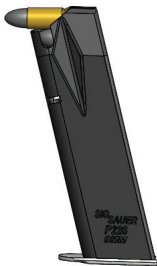

STEPS 1, 2



STEP 3

CAPACITY
INDICATOR
WINDOW

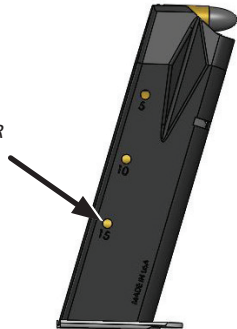

3.4 LOADING THE PISTOL READY TO FIRE

1. Keep the muzzle pointed in a safe direction.
2. Fully retract the slide and lock it to the rear by pushing up on the slide catch lever.
3. For SAO pistols, rotate the manual safety lever upward to engage the manual safety.
4. Visually and physically inspect the chamber to ensure it is clear of ammunition and foreign debris.
5. Visually and physically inspect the breech face and magazine well to ensure it is clear of ammunition and foreign debris.



STEP 2

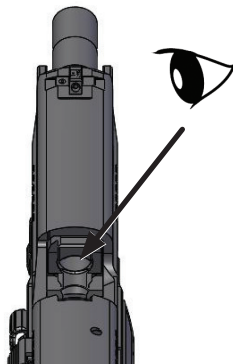

STEP 4

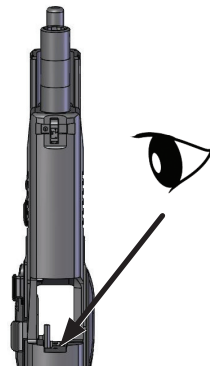

STEP 5



3.4 LOADING THE PISTOL READY TO FIRE (CONTINUED)

6. Insert a loaded magazine by pushing it up into frame until it locks in place. You should hear an audible click.



STEP 6

CAUTION

DO NOT RIDE THE SLIDE FORWARD. FAILURE TO PROPERLY COMPLETE STEP 7 (b) MAY INDUCE A STOPPAGE.

7. To chamber a cartridge release the slide by either:
 - a. Pressing down on the slide catch lever.
 - b. Pulling back on the slide until the slide catch lever drops clear of the slide then, releasing the slide.

**WARNING****LOADED PISTOL**

THE PISTOL IS NOW LOADED AND READY TO FIRE.



3.4 LOADING THE PISTOL READY TO FIRE (CONTINUED)

8. For DA/SA pistols, push down on the decocking lever to decock the hammer.

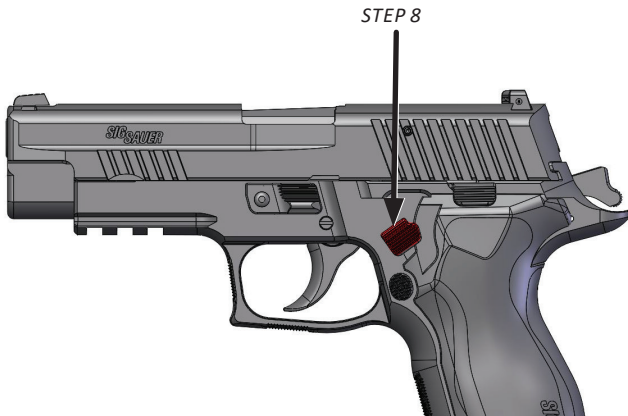

3.5 RELOADING DURING SHOOTING MAGAZINE DEPLETED

NOTE

Upon firing the last round in the pistol, the empty magazine will engage the slide catch lever and lock the slide in the open position.

1. For SAO pistols, rotate the manual safety lever upward to engage the manual safety.
2. Press the magazine catch to release the empty magazine.
3. Insert a loaded magazine by, pushing it up and into the magazine well until it locks in place. You should hear an audible click.





3.5 RELOADING DURING SHOOTING MAGAZINE DEPLETED (CONTINUED)

4. To chamber a round, release the slide by either:
 - a. Pressing down on the slide catch lever.
 - b. Pulling back on the slide until the slide catch lever drops clear of the slide then, releasing the slide.

STEP 4 (a)



STEP 4 (b)



WARNING

LOADED PISTOL



THE PISTOL IS NOW LOADED AND READY TO FIRE.

5. For DA/SA pistols, push down on the decocking lever to decock the hammer.

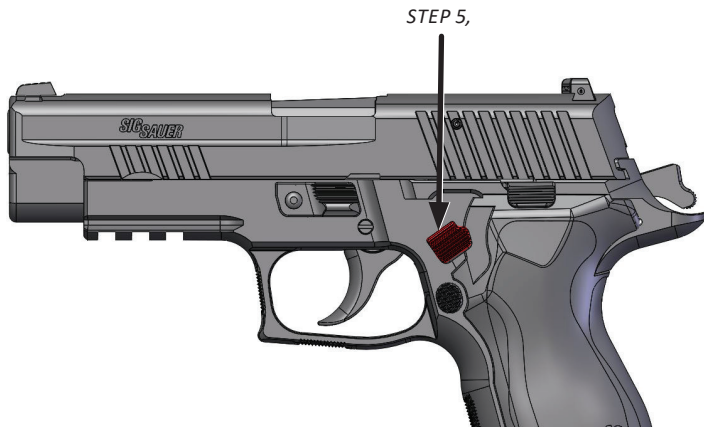



3.6 RELOADING DURING SHOOTING PARTIAL MAGAZINE

NOTE

A magazine does not need to be empty to be removed.

1. Keep the muzzle pointed in a safe direction.
2. For DA/SA pistols, push down on the decocking lever to decock the hammer.
3. For SAO pistols, rotate the manual safety lever upward to engage the manual safety.

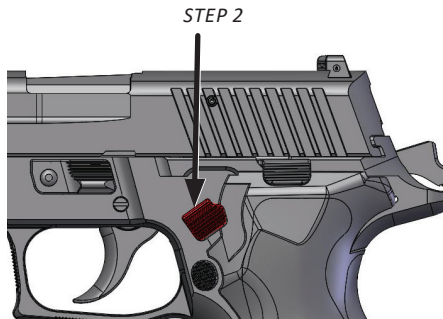

4. Press the magazine catch to remove the loaded magazine.

**WARNING****LOADED PISTOL****THE PISTOL IS STILL LOADED AND READY TO FIRE.**

5. Insert a loaded magazine by, pushing it up and into the magazine well until it locks in place. You should hear an audible click.



STEP 4

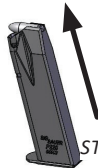
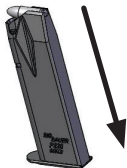

STEP 5



4.0 FIRING



WARNING

LOADED PISTOL



DO NOT TOUCH THE TRIGGER UNTIL YOU ARE ACTUALLY READY TO FIRE THE PISTOL.

Keep the muzzle pointed in a safe direction, your finger off of the trigger and out of the trigger guard when cycling the slide of any pistol.

Never discharge any firearm with your finger, hand, face, or other part of your body over or adjacent to the ejection port, or in any position where you may be struck by the reciprocating movement of the slide. Both the ejection of empty cartridge cases and the movement of the slide are part of the normal operating cycle of firearms and pose no safety hazard to the shooter if the firearm is held in a normal grip and fired at arm's length.

Never allow other persons to stand beside you where they might be struck by an ejected cartridge case. The case is hot and may be ejected with sufficient force to cause a burn, cut, or other injury. Wear safety glasses to protect your eyes. Make certain that there is a clear, unobstructed path for safe ejection of the fired case. Remember, the case might bounce off a hard object nearby and strike you or someone else.

4.1 FIRING THE PISTOL



WARNING

EJECTION



THE SLIDE OPENS AND SHUTS QUICKLY WHILE FIRING. KEEP FACE AND HANDS AWAY FROM IT. HOT BRASS, UNBURNT POWDER, AND GAS IS EJECTED QUICKLY AND CAN BURN YOU. ALWAYS WEAR SAFETY GLASSES AND HEARING PROTECTION.

1. Aim the pistol at a safe target.
2. For SAO pistols, push down on the manual safety lever to disengage the manual safety.
3. Press the trigger rearward to discharge





4.1 FIRING THE PISTOL (CONTINUED)

4. Keep the pistol aimed at the target and continue to fire as desired or until the magazine is empty.
5. Remove your finger from the trigger.
6. For DA/SA pistols, push down on the decocking lever to decock the hammer.
7. For SAO pistols, rotate the manual safety lever upward to engage the manual safety.

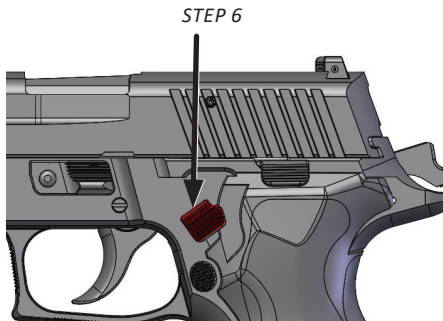

8. To unload and clear the pistol proceed to *STEP 4* of (section, “5.1 Unloading the Pistol Magazine Not Empty” on page 47)
9. To resume firing, keep the pistol aimed at a safe target.
10. For SAO pistols, push down on the manual safety lever to disengage the manual safety.
11. Continue to fire the pistol as desired or until the magazine is empty.
12. Upon firing the last round in the pistol, the empty magazine will engage the slide catch lever and lock the slide open. To unload and clear the pistol proceed to, (section, “5.2 Unloading the Pistol Magazine Empty, Slide Open” on page 50). To continue firing, reload the pistol, as described in, (section, “3.5 Reloading During Shooting Magazine Depleted” on page 37).

**WARNING****SAFETY**

DO NOT LOWER THE HAMMER BY PRESSING THE TRIGGER AND ATTEMPTING TO MANUALLY EASE THE HAMMER FORWARD. MANUALLY LOWERING THE HAMMER PREVENTS THE FULL APPLICATION OF THE OTHER SAFETY FEATURES OF THIS PISTOL. FAILURE TO COMPLY WITH THIS WARNING CAN RESULT IN UNINTENTIONAL DISCHARGE, INJURY OR DEATH, OR DAMAGE TO PROPERTY.

NOTE

For DA/SA pistols, push down on the decocking lever to decock the hammer.
For SAO pistols, proceed to (section, “5.1 Unloading the Pistol Magazine Not Empty” on page 47) to lower the hammer.



5.0 UNLOADING THE PISTOL



WARNING

UNLOAD/CLEAR



WHEN THERE IS A CARTRIDGE IN THE CHAMBER, THE CARTRIDGE WILL DISCHARGE IF THE TRIGGER IS PRESSED. IT IS ABSOLUTELY ESSENTIAL FOR THE USER TO KNOW HOW TO COMPLETELY UNLOAD THE PISTOL. "COMPLETELY" MEANS EMPTYING THE MAGAZINE AND REMOVING A CHAMBERED CARTRIDGE. REMOVING THE MAGAZINE FROM THE PISTOL DOES NOT PREVENT IT FROM BEING FIRED. A PISTOL WILL FIRE A CHAMBERED CARTRIDGE EVEN WITH MAGAZINE REMOVED.

1. Always make sure the muzzle is pointed in a safe direction! Remember to clear the chamber after the magazine has been removed.
2. Never assume that any firearm is unloaded until you have personally checked it, visually and physically!
3. After every range session, make a final check to be certain the firearm is unloaded before leaving the range.

5.1 UNLOADING THE PISTOL MAGAZINE NOT EMPTY

1. Keep the muzzle pointed in a safe direction.
2. For DA/SA pistols, push down on the decocking lever to decock the hammer.
3. For SAO pistols, rotate the manual safety lever upward to engage the manual safety.
4. Press the magazine catch and remove the magazine.
5. Pull the slide completely to the rear while watching for the ejection of a live cartridge and push up on the slide catch lever, to lock the slide open.



STEP 4

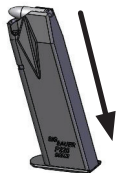

STEP 5



5.1 UNLOADING THE PISTOL MAGAZINE NOT EMPTY (CONTINUED)

6. Visually and physically check the chamber to ensure that the pistol is completely free of ammunition.
7. Visually and physically check the breech face, and magazine well to ensure that the pistol is completely free of ammunition
8. Press down on the slide catch lever, to close the slide.

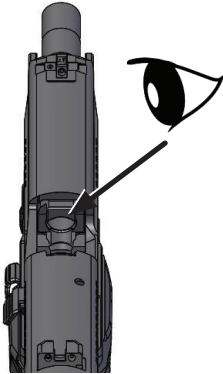

STEP 6

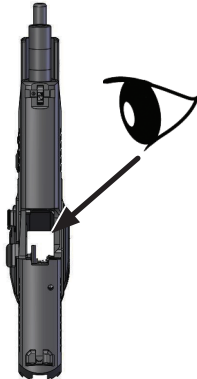

STEP 7



9. Keep the muzzle pointed in a safe direction.
10. For DA/SA pistols, push down on the decocking lever to decock the hammer and proceed to *STEP 13*.
11. For SAO pistols, push down on the manual safety lever to disengage the manual safety.
12. Press the trigger rearward to release the hammer.
13. Unload the magazine.



STEP 13



5.2 UNLOADING THE PISTOL MAGAZINE EMPTY, SLIDE OPEN

1. Keep the muzzle pointed in a safe direction.
2. For SAO pistols, rotate the manual safety lever upward to engage the manual safety.
3. Press the magazine catch and remove the magazine.
4. Visually and physically check the chamber to ensure that the pistol is completely free of ammunition.
5. Visually and physically check the breech face, and magazine well to ensure that the pistol is completely free of ammunition.
6. Press down on the slide catch lever, to close the slide.

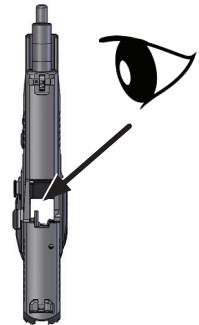
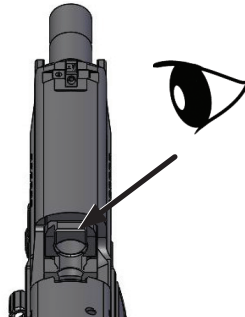

7. Keep the muzzle pointed in a safe direction.
8. For DA/SA pistols, push down on the decocking lever to decock the hammer and proceed to *STEP 11*.
9. For SAO pistols, push down on the manual safety lever to disengage the manual safety.
10. Press the trigger to release the hammer.
11. Unload the magazine.



STEP 11



6.0 PROCEDURES IN CASE OF STOPPAGE

Follow the immediate action procedures if:

- You notice that a cartridge is difficult to chamber.
- A cartridge does not fire.
- The extractor fails to extract a fired cartridge case.
- You discover unburned grains of propellant powder spilled in the fire control assembly.
- A shot sounds or feels weak or abnormal.



WARNING

STOPPAGE



LIVE ROUND MAY NOT EJECT. UNLOAD/CLEAR PISTOL

Firearms work reliably if properly maintained. If there is a stoppage during firing:

1. Keep the pistol pointed in a safe direction with your finger off the trigger and engage manual safety or press the decocking lever if so equipped.
2. Remove and secure the magazine.
3. Cycle the slide rearward and forward to clear any live cartridge or expended case in or near the chamber. Visually and physically inspect the breech face and chamber.
4. If you suspect that a bullet is lodged in the bore, field strip your pistol and check to see if the barrel is blocked. If there is a bullet lodged in the bore, return the pistol to SIG SAUER see, (section, "11.3 Shipping Firearms for Repair" on page 88).

**WARNING****STOPPAGE**

IF A BULLET IS IN THE BORE, DO NOT ATTEMPT TO SHOOT IT OUT BY USING ANOTHER CARTRIDGE, OR BY BLOWING IT OUT WITH A BLANK OR A CARTRIDGE FROM WHICH THE BULLET HAS BEEN REMOVED. THIS CAN GENERATE EXCESSIVE PRESSURE, DAMAGE THE FIREARM AND CAUSE SERIOUS PERSONAL INJURY OR DEATH TO YOURSELF OR OTHERS.

6.1 TROUBLESHOOTING GUIDE

Stoppage	Cause	Correction
<i>Feed</i>		
No round fed into the chamber	Magazine not properly inserted or magazine is deformed or dirty	Insert magazine properly or change magazine
Slide does not close easily or completely	Pistol or cartridge is fouled (dirty) or pistol is too heavily lubricated	Clean and lubricate pistol and/or replace the ammunition
	Incorrect ammunition	Replace ammunition
	Pistol requires service	Return to SIG SAUER



6.0 PROCEDURES IN CASE OF STOPPAGE (CONTINUED)

Stoppage	Cause	Correction
<i>Failure to Extract or Eject</i>		
After firing, the case stays in the chamber or is jammed in the ejection port	Insufficient recoil due to dirt	Clean and lubricate the pistol
	Light hold or limp wrist	Solid grip, rigid hold
	Low-powered ammunition	Change ammunition
	Pistol requires service	Return to SIG SAUER
<i>Failure to Fire</i>		
Hammer drops but round does not fire	Faulty ammunition	Manually cycle in next round
	Firing pin obstructed	Inspect, clean and lubricate the pistol
	Pistol requires service	Return to SIG SAUER

6.2 MINIMIZING STOPPAGES

Stoppages can largely be avoided by cleaning and lubricating the pistol see, (section, “7.3 Cleaning the Pistol” on page 60).

Cleaning and lubricating your pistol after each range session will reduce the chances of a stoppage in the cycle of operation due to dirt and residue buildup.

Perform maintenance if the firearm is exposed to extreme environmental conditions (rain, snow, freezing temperatures, etc.).

Periodically inspect the pistol if it is stored for extended periods of time without use. Most stoppages are directly related to the magazine. Perform maintenance of your magazines as well as the firearm.

A good practice is to mark the base plates of the magazines so that you can identify a magazine that causes stoppages.



WARNING

COOK-OFF



IF YOUR PISTOL STOPS FIRING WITH A LIVE ROUND IN THE CHAMBER OF A HOT BARREL (A MISFIRE OR STOPPAGE), REMOVE THE ROUND IMMEDIATELY. IF YOU CANNOT REMOVE THE ROUND WITHIN 10 SECONDS, REMOVE THE MAGAZINE AND WAIT AT LEAST 15 MINUTES WITH THE PISTOL POINTING IN A SAFE DIRECTION. THIS WAY, NEITHER THE USER NOR ANY OTHER PERSON WOULD BE INJURED BY THE POSSIBILITY OF A ROUND “COOKING-OFF” (A ROUND DETONATING DUE TO THE HEAT OF THE BARREL). KEEP YOUR FACE AWAY FROM THE EJECTION PORT WHILE CLEARING A HOT CHAMBER.



7.0 MAINTENANCE



WARNING

UNLOAD/CLEAR



VERIFY THAT THE MAGAZINE IS REMOVED, VISUALLY AND PHYSICALLY CONFIRM THAT THE PISTOL IS UNLOADED AND CLEARED BEFORE ATTEMPTING DISASSEMBLY OR PERFORMING ANY MAINTENANCE STEPS. FAILURE TO ENSURE THAT THE FIREARM IS UNLOADED AND CLEARED COULD RESULT IN UNINTENTIONAL DISCHARGE, CAUSING SEVERE INJURY OR DEATH, OR PROPERTY DAMAGE. VERIFY THAT THE FIREARM IS UNLOADED AND CLEARED.

7.1 PISTOL DISASSEMBLY

1. Unload and clear the pistol see, (section, “5.0 Unloading the pistol” on page 46).

NOTE

For Steps 2 & 3, refer to the illustration on the pages.

2. Lock the slide to the rear by pulling slide rearward and pushing up on the slide catch lever.
3. Rotate the takedown lever clockwise until it stops.

7.1 PISTOL DISASSEMBLY (CONTINUED)

**WARNING PARTS UNDER SPRING TENSION****SLIDE IS UNDER SPRING TENSION. MAINTAIN POSITIVE CONTROL DURING SLIDE REMOVAL TO PREVENT DAMAGE OR INJURY. WEAR EYE PROTECTION****NOTE**

Please be advised that earlier model SIG SAUER pistols (especially P220) equipped with a SRT (Short Reset Trigger) might require an different procedure for disassembly. For those pistols refer to (“Appendix A: SRT Supplemental Instructions” on page 97).

- Retract the slide slightly to disengage the slide catch lever. Allow the slide to move forward in a controlled fashion.
- Move the complete slide assembly (slide, barrel, recoil spring and guide) forward and off the frame.



STEP 2

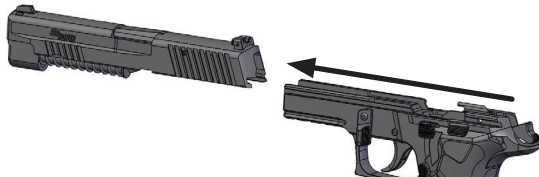

STEP 4, 5



WARNING PARTS UNDER SPRING TENSION



THE RECOIL SPRING AND GUIDE ARE UNDER SPRING TENSION AND NOT FIRMLY ATTACHED TO THE SLIDE. USE CAUTION TO PREVENT INJURY OR DAMAGE TO THE PISTOL. WEAR EYE PROTECTION.

6. Push the recoil guide forward slightly and lift it from rear to remove the recoil spring and guide from the slide.
7. Remove the barrel from the slide by pulling upward slightly and to the rear. This level of disassembly is sufficient to allow a thorough cleaning after shooting.



STEP 6



STEP 7

NOTE

This level of disassembly is sufficient to allow a thorough cleaning after firing.

7.2 MAGAZINE DISASSEMBLY

1. Locate the bottom of the magazine floor plate.



WARNING PARTS UNDER SPRING TENSION



THE MAGAZINE SPRING IS COMPRESSED. GUARD THE MAGAZINE INSERT AND MAGAZINE SPRING. UNCONTROLLED RELEASE CAN CAUSE INJURY. WEAR EYE PROTECTION.

2. Using a punch or similar tool to press the magazine insert in and push the magazine floor plate forward until it is clear of the magazine tube.
3. Remove the magazine spring and magazine follower from the magazine tube.

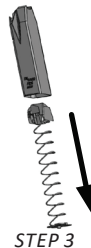
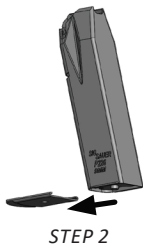
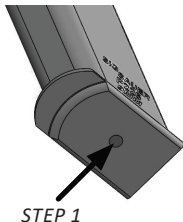



7.3 CLEANING THE PISTOL



WARNING CLEANING



**READ AND FOLLOW THE MANUFACTURER'S WARNINGS BEFORE USING SOLVENTS OR CLEANERS.
WEAR EYE PROTECTION.**

CAUTION

NEVER CLEAN THE BARREL FROM THE MUZZLE END, CLEANING FROM THE MUZZLE END COULD CAUSE DAMAGE TO THE CROWN OR THE RIFLING OF THE BARREL; DO NOT USE A STEEL WIRE BRUSH AS IT CAN DAMAGE THE SMOOTH SURFACE OF THE BARREL. USE A SUITABLE CLEANING ROD AND BRONZE BRUSH OF THE CORRECT CALIBER. SOLVENTS CAN BE HARMFUL TO THE SURFACE FINISH OF THE PISTOL. AVOID OVER-LUBRICATION OF COMPONENTS.

CAUTION

DO NOT LUBRICATE THE FIRING PIN OR FIRING PIN SAFETY LOCK. DO NOT ALLOW LUBRICANT TO FLOW INTO THE FIRING PIN OR FIRING PIN SAFETY LOCK CHANNEL OF THE SLIDE. THIS MAY CAUSE A LIGHT STRIKE TO THE CARTRIDGE RESULTING IN A FAILURE TO FIRE.

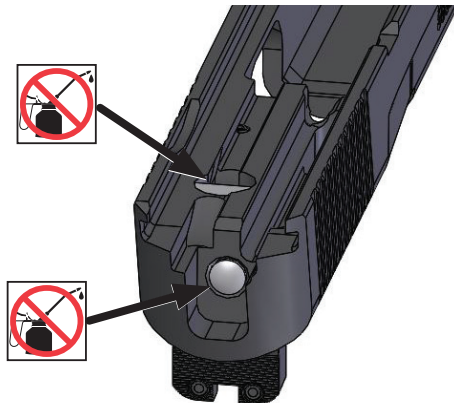



7.3 CLEANING THE PISTOL (CONTINUED)

MATERIALS REQUIRED

- Cleaning patches
- Rag, wiping
- Bore brush of the proper caliber
- Cleaning rod
- CLP (Cleaning, Lubricant, Protective)
- TW-25B (Lubricating grease)
- Lubricant, Low Temperature when applicable
- Brush, cleaning

The following instructions are for normal environmental conditions. Clean and lube before or after every day the pistol is fired or at a minimum of every 500 rounds

NOTE

TW-25B or similar lubricant designed for stainless steel is recommended for “All Stainless” models. CLP is recommended for general lubrication but, any lubricant designed specifically for firearms may be used.

SLIDE ASSEMBLY

1. Remove all of the old lubricant before you reapply.
2. Clean the slide assembly with a cloth. A soft brush and CLP can be used to clean excessive dirt and carbon buildup. Ensure the extractor, rail slots and breech face are free of dirt and residue.
3. Apply a light coat of CLP to the frame rail slots of the slide.
4. Lightly oil all external parts.
5. Do not lubricate the firing pin.

BARREL

1. Soak a patch with CLP and push it through the bore from the chamber end and out past the muzzle.
2. Allow the CLP to soak for a while to loosen residue and soften carbon deposits.
3. Wipe the exterior of the barrel with a cloth soaked in CLP.
4. Repeat step #1.
5. Use the bore brush and a cleaning rod to scrub heavy deposits from the bore.
6. Repeat step #1.
7. Push dry patches through the bore until they come out clean.
8. Lightly oil bore and chamber if the pistol is to be stored for a period of time.
9. Always remove any lubricant from the bore prior to firing the pistol.



7.3 CLEANING THE PISTOL (CONTINUED)

RECOIL SPRING AND GUIDE

1. Clean the recoil spring guide with CLP and a soft brush.
2. After cleaning, apply a light coat of CLP.

FRAME ASSEMBLY

1. Wipe the frame with a soft cloth.
2. Use cotton swabs to clean hard to reach areas. Pay special attention to the frame rails, takedown lever and slide catch lever.
3. Lubricate the frame rails with a light coat of CLP.
4. Apply CLP to accessible functioning parts.
5. Clean the magazine well of any dirt, dust or residue with a soft cloth.

MAGAZINE

1. Wipe the magazine tube and follower with a cloth. Clean the magazine tube and follower with a soft brush and CLP.
2. Use a cloth to clean the magazine spring, floor plate, and base plate.
3. Apply a light coat of CLP to the spring and magazine tube.

THIS PAGE INTENTIONALLY LEFT BLANK



7.4 PISTOL ASSEMBLY

1. Verify that the each part is clear of all foreign matter.
2. Insert the barrel into the slide.



WARNING PARTS UNDER SPRING TENSION



THE RECOIL SPRING AND GUIDE ARE UNDER SPRING TENSION AND NOT FIRMLY ATTACHED TO THE SLIDE. USE CAUTION TO PREVENT INJURY OR DAMAGE TO THE PISTOL. WEAR EYE PROTECTION.

3. Insert recoil spring and guide into the slide.



STEP 2

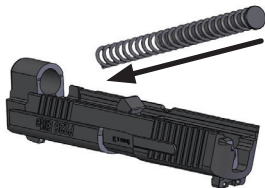

STEP 3

4. Ensure the takedown lever is rotated clockwise to the vertical position (6 o'clock).
5. Guide the slide onto the frame rails from the front.
6. Retract the slide fully to the rear and push up on the slide catch lever to lock the slide in the open position.



STEP 4



STEPS 5, 6



7.4 PISTOL ASSEMBLY (CONTINUED)

7. Rotate the takedown lever counterclockwise until horizontal.
8. Press the slide catch lever to release the slide.
9. For DA/SA pistols, push down on the decocking lever to decock the hammer.



7.5 MAGAZINE ASSEMBLY

1. Position the magazine follower on the magazine spring and insert into the bottom of the magazine tube.



WARNING PARTS UNDER SPRING TENSION



THE MAGAZINE SPRING IS BEING COMPRESSED DURING ASSEMBLY. GUARD THE MAGAZINE INSERT AND MAGAZINE SPRING. UNCONTROLLED RELEASE CAN CAUSE INJURY. WEAR EYE PROTECTION.

2. Insert the magazine spring fully into the magazine tube until the magazine insert is flush with the magazine tube bottom.
3. Holding the magazine insert in place, slide the magazine floor plate onto the magazine tube lips until the magazine floor plate is locked in place by the magazine insert.

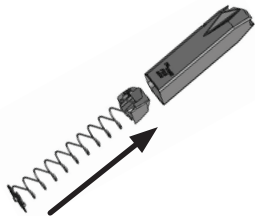

STEP 1

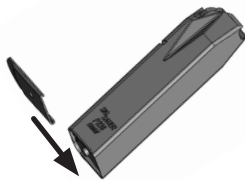

STEP 3



7.6 FUNCTION CHECK

The function check is performed on the assembled pistol to verify functionality. It should be performed after the completion of repairs and after each cleaning and assembly of the pistol.



WARNING

UNLOAD/CLEAR



VERIFY THE MAGAZINE IS REMOVED. VISUALLY AND PHYSICALLY CONFIRM THE PISTOL IS UNLOADED AND CLEARED BEFORE THE BEGINNING OF THE FUNCTION CHECK. FAILURE TO ENSURE THE FIREARM IS UNLOADED AND CLEARED COULD RESULT IN UNINTENTIONAL DISCHARGE, CAUSING SEVERE INJURY OR DEATH, OR PROPERTY DAMAGE. VERIFY THE FIREARM IS UNLOADED AND CLEARED.

1. Ensure that the magazine is removed and the pistol is unloaded (section, “5.0 Unloading the pistol” on page 46).
2. Keep the muzzle pointed in a safe direction.
3. Check recoil spring function/slide travel.
 - a. Retract the slide completely to the rear and release it a minimum of two times.
 - b. Verify the slide is consistently closing and fully locking into position.
4. Check the trigger mechanism:
 - a. DA/SA.
 1. Press decocking lever to decock hammer.
 2. Press trigger to rear and hold. Hammer should cock and release.
 3. Pull back slide and release. Release trigger. Hammer should be in single action position.
 4. Press trigger. Hammer should release from single action position.
 5. Release trigger and push forward on hammer spur. Hammer must not contact firing pin.
 - b. DAO/DAK
 1. Press trigger. Hammer must cock and release.
 - c. SAO
 1. Pressing the trigger will release the hammer from its cocked position once the manual safety is disengaged.



7.6 FUNCTION CHECK (CONTINUED)

2. Check slide catch lever.

- a. Insert an empty magazine.
- b. Retract the slide fully and release.
- c. Verify the slide is locked to the rear by the slide catch lever.
- d. Press the slide catch lever.
- e. Verify the slide is released and closes in the fully locked position.
- f. Remove the magazine.



3. Inspect the magazine.

- a. Check the condition of the magazine tube.
- b. Verify the magazine floor plate is secure.
- c. Press down on the follower to check for free movement of the magazine follower and spring.
- d. Insert the magazine into the pistol, verify smooth insertion.
- e. Press the magazine catch and check for proper engagement and smooth release.



STEP 3 (a, b, c)

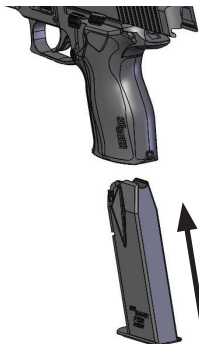

STEP 3 (d)



STEP 3 (e)



7.6 FUNCTION CHECK (CONTINUED)

4. Inspect the pistol exterior.
 - a. Inspect the general condition of the pistol.
 - b. Check the sights, body, slide, and takedown lever for damage.
 - c. Verify the front and rear sights are secure.

CAUTION

NEVER USE A FIREARM OR MAGAZINE THAT SHOWS SIGNS OF DAMAGE OR FAILS A FUNCTION CHECK. VERIFY THE MAGAZINE IS THE CORRECT MODEL AND CALIBER FOR THE PISTOL. IF THE CONDITION OR FUNCTION OF THE PISTOL OR MAGAZINE IS SUSPECT, RETURN THE PISTOL OR MAGAZINE TO SIG SAUER FOR EVALUATION.

VERIFY THE CONDITION AND FUNCTION.

8.0 MAGAZINE CATCH REMOVAL AND REVERSAL

The classic line pistol is designed for both right hand and left hand operation. The magazine catch may be repositioned to either side based on shooter preference.



WARNING

UNLOAD/CLEAR



VERIFY THE MAGAZINE IS REMOVED, VISUALLY AND PHYSICALLY CONFIRM THE PISTOL IS UNLOADED AND CLEARED BEFORE ATTEMPTING DISASSEMBLY OR PERFORMING ANY MAINTENANCE STEPS. FAILURE TO ENSURE THE FIREARM IS UNLOADED AND CLEARED COULD RESULT IN UNINTENTIONAL DISCHARGE, CAUSING SEVERE INJURY OR DEATH, OR PROPERTY DAMAGE. VERIFY THE FIREARM IS UNLOADED AND CLEARED.



8.1 MAGAZINE CATCH REMOVAL

Before removing and reversing the magazine catch ensure the pistol is completely unloaded and cleared. Removing the slide as described in (section, “7.1 Pistol Disassembly” on page 56), will provide better access to the magazine catch.

1. Press the magazine catch until the back protrudes slightly from the opposite side and hold.
2. On the protruding side, press the straightened end of a paper clip into the hole on the back side of the magazine catch to release the magazine catch stop.
3. Remove the magazine catch stop.
4. Remove the magazine catch and magazine catch spring, keeping the two pieces together.

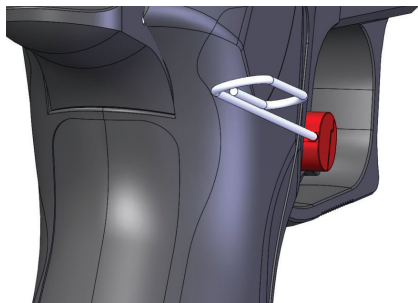

STEPS 1, 2

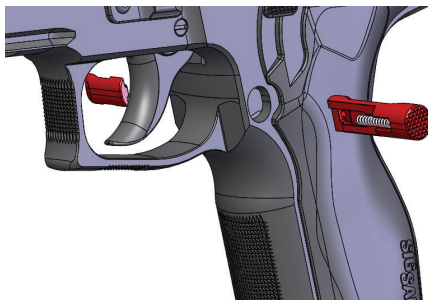

STEPS 3, 4

8.2 MAGAZINE CATCH INSTALLATION

5. Insert the magazine catch and magazine catch spring on the desired side of the pistol body.
6. Press the magazine catch into the frame until it protrudes out the opposite side and hold it in position.
7. Insert the magazine catch stop from the opposite side until the magazine catch stop latch engages and release the magazine catch..



STEP 5

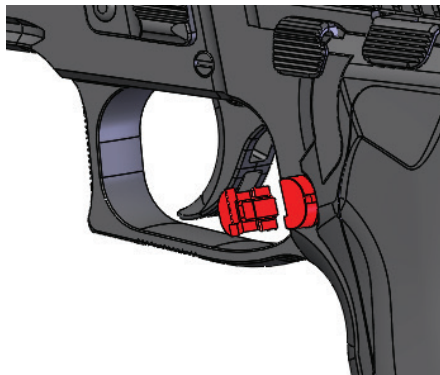

STEP 6-7



9.0 SIGHTS



WARNING

TRITIUM SIGHTS



SOME SIG SAUER PISTOLS COME EQUIPPED WITH SIGHTS THAT CONTAIN RADIOACTIVE MATERIAL FOR ILLUMINATION DURING LOW LIGHT CONDITIONS OR HOURS OF DARKNESS. THE SIGHTS ARE MARKED WITH THE LETTERS "SIG" AND "H3." THE RADIATION SOURCE IS HYDROGEN-3 (H3), COMMONLY KNOWN AS TRITIUM. THE ACTIVITY LEVEL OF TRITIUM IN SIG SAUER NIGHT SIGHTS RANGE FROM 12 MCI (MILLCURIES) TO 30 MCI. THE OPERATIONAL TEMPERATURE RANGE OF SIG SAUER TRITIUM SIGHTS IS $-30^{\circ}\text{C}/-22^{\circ}\text{F}$ TO $+60^{\circ}\text{C}/+140^{\circ}\text{F}$. THE BETA RADIATION EMITTED BY TRITIUM IS ONLY A HAZARD IF THE TRITIUM VIAL IS BROKEN AND IS INGESTED OR INHALED BY HUMANS. THE BODY DOES NOT EASILY RETAIN HYDROGEN OR TRITIUM AS A GAS. HOWEVER, THE OXIDE HTO, WHICH IS FORMED BY THE BURNING OF TRITIUM IS 10,000 TIMES MORE HAZARDOUS. FOR THIS REASON GREAT CARE SHOULD BE TAKEN TO AVOID FLAME IN THE PRESENCE OF DAMAGED TRITIUM SIGHTS. DISPOSAL OF TRITIUM SIGHTS MUST BE PERFORMED IN A CONTROLLED MANNER. IF YOU SUSPECT THAT THE SIGHT CONTAINING A TRITIUM VIAL HAS BROKEN, DO NOT ATTEMPT TO DISASSEMBLE THE SIGHT. FOLLOW THESE INSTRUCTIONS.

DAMAGED SIGHTS ONLY (SIGHTS REMOVED FROM FIREARM):

PLACE DAMAGED SIGHTS IN A SMALL ZIP LOCK BAG AND LABEL IT "DAMAGED TRITIUM SIGHT DO NOT OPEN," PLACE THE ZIP LOCK BAG IN A SHIPPING ENVELOPE MARKED "NIGHT SIGHT FOR DISPOSAL" AND SEND TO:

**SIG SAUER, INC.
357 SIG SAUER DRIVE
JACKSONVILLE, AR 72076**

SLIDE WITH DAMAGED SIGHTS:

CALL CUSTOMER SERVICE AT (603) 610-3000 EXT.1 FOR INSTRUCTIONS AND RETURN AUTHORIZATION.

**WARNING****TRITIUM SIGHTS****DO NOT DISCARD TRITIUM SIGHTS IN THE TRASH**

AFTER CONTACT WITH A SUSPECTED DAMAGED TRITIUM SIGHT, WASH YOUR HANDS CAREFULLY WITH SOAP AND WATER. DO NOT HANDLE DAMAGED SIGHTS IF YOU HAVE OPEN SKIN CUTS OR ABRASIONS. DO NOT EAT, DRINK, SMOKE OR APPLY COSMETICS IN THE PRESENCE OF A DEFECTIVE SIGHT VIAL.



9.1 GENERAL INFORMATION

The SIG SAUER Classic line pistol is equipped with drift-adjustable fixed sights that have proven their worth under severe conditions. The sights consist of a rear sight and a front sight blade, designed and dimensioned to ensure rapid target acquisition even when visibility is poor.

CAUTION

SIG SAUER SUGGESTS THAT FIXED-SIGHT CORRECTIONS SHOULD BE PERFORMED ONLY BY A CERTIFIED SIG SAUER ARMORER OR CERTIFIED GUNSMITH. OTHERWISE THE PISTOL COULD BECOME DAMAGED.

9.2 WINDAGE (LEFT/RIGHT) ADJUSTMENT



WARNING

SIGHT ADJUSTMENT



SIGHT CORRECTIONS SHOULD ONLY BE PERFORMED ON AN UNLOADED FIREARM. MANIPULATING THE SIGHTS ON A LOADED FIREARM COULD RESULT IN UNINTENTIONAL DISCHARGE, CAUSING SEVERE INJURY OR DEATH, OR PROPERTY DAMAGE. VISUALLY AND PHYSICALLY CONFIRM THE PISTOL IS UNLOADED AND CLEARED BEFORE MAKING SIGHT ADJUSTMENTS. DO NOT ADJUST SIGHTS ON A LOADED FIREARM.

Change windage by moving the rear sight either to the left or right in its dovetail. When you do this, follow the rear sight rule: Move the rear sight in the direction you want the group to go. Moving the rear sight 0.020" in the dovetail changes the point of impact by approximately 3" at 25 yards.

NOTE

SIG SAUER has a Sight Adjustment Tool available that makes it easier to adjust and change fixed sights.

Impact left of point of aim

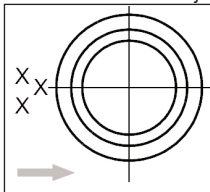



9.3 ELEVATION (UP/DOWN) ADJUSTMENT

There are different height combinations available for the front and rear sights. The sights are numbered according to their height. You can change elevation by changing either the rear or front sight. It's easier if you change the rear sight first. There are six rear sight heights available. Each rear sight change will move the impact of the bullet approximately 2" at 25 yards. There are five front sight heights available. Each front sight change will move the impact of the bullet approximately 1" at 25 yards.

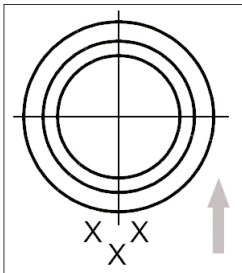

Impact low of point of aim

When changing sights, remember this rule: **NUMBERS UP, GROUPS UP; NUMBERS DOWN, GROUPS DOWN.** This is true for both front and rear sights.

10.0 STORAGE AND TRANSPORTATION

10.1 STORAGE



WARNING

UNLOAD/CLEAR



YOU MUST UNLOAD AND CLEAR THE FIREARM PRIOR TO STORING THE PISTOL (SEE SECTION 5.0).

Never place or store any firearm in such a manner that it may be dislodged. Firearms should always be stored securely and unloaded, away from children and other unauthorized users. Use the locking device originally supplied with this firearm for storage. The use of a locking device or safety lock is only one aspect of responsible firearms storage. For increased safety, firearms should be stored unloaded and locked in a location that is both separate from their ammunition and inaccessible to children and any other unauthorized person.



SHORT-TERM STORAGE (90 DAYS OR LESS)

1. Ensure that the chamber and magazine do not contain live ammunition.
2. Clean the bore and chamber.
3. Apply a light coat of CLP to the chamber and bore.
4. Apply a light coat of CLP to all other metal surfaces for corrosion protection.

LONG-TERM STORAGE (90 DAYS OR LONGER)

1. Ensure that the pistol is thoroughly cleaned.
2. Apply a heavy coat of CLP to the chamber and bore.
3. Apply a heavy coat of CLP to all other metal surfaces for corrosion protection.
4. Wrap the firearm with a waterproof material (MIL-B-121 or similar).
5. Place the firearm in a corrosion resistant barrier bag (MIL-DTL-117 or similar).

ENVIRONMENTAL STORAGE

Provide humidity control to limit the relative humidity to no greater than 40% RH at 80 degrees Fahrenheit (26.7 degrees Celsius). If personnel will be working in these areas, design to 68 degrees F (20.0 degrees C) dry bulb and 40% RH for indoor design heating conditions, and 75 degrees F (23.9 deg C) dry bulb and 40% RH for indoor design cooling conditions.

10.2 TRANSPORTATION



WARNING

UNLOAD/CLEAR



**YOU MUST UNLOAD AND CLEAR THE FIREARM PRIOR TO TRANSPORTING THE PISTOL
SEE, (SECTION, "5.0 UNLOADING THE PISTOL" ON PAGE 46).**

IT IS YOUR RESPONSIBILITY TO FAMILIARIZE YOURSELF WITH THE LAWS OF ANY STATE YOU ARE PLANNING TO TRAVEL THROUGH WITH YOUR FIREARM.

When transporting your firearm to and from shooting activities, keep it unloaded for your safety and for the safety of others. When storing your firearm for transportation, keep it separated from ammunition, under lock and key if possible, and out of the reach of children and other inexperienced or unauthorized persons. If transporting the firearm in a vehicle, ensure that it is secured within the confines of the vehicle. Should the vehicle become involved in an accident, you do not want the firearm to become dislodged and move about the interior of the vehicle or be ejected from the vehicle.



11.0 PARTS AND SERVICE POLICY

11.1 PARTS POLICY



WARNING

PARTS REPLACEMENT



IMPROPER FITTING OF PARTS MAY RESULT IN A DANGEROUS MALFUNCTION, DAMAGE TO THE FIREARM, AND SERIOUS INJURY TO THE SHOOTER AND OTHER PERSONS.

Our Service Department maintains a full complement of replacement parts. Even though most gunsmiths have the knowledge, training, and the ability to make necessary repairs to your firearm, the skill and workmanship of any particular gunsmith is totally beyond our control.

Should your firearm ever require service, we strongly recommend that you return it to SIG SAUER. A firearm is a precision instrument and some replacement parts will require individual fitting to ensure correct operation. A wrong part, improper fitting, or incorrect mechanical adjustment may result in an unsafe condition or dangerous malfunction, damage to the firearm, or cause possible serious injury to the shooter or others.

IF ANY PART IS ORDERED WITHOUT RETURNING THE FIREARM TO SIG SAUER INC., the customer bears full responsibility for ensuring that the part supplied is correct for their particular firearm and is properly installed and fitted by a qualified gunsmith.

It is the purchaser's responsibility to be absolutely certain that any parts ordered from the factory are correctly fitted and installed. Firearms are complicated mechanisms and the purchaser and installer of parts must accept full responsibility for the correct adjustment and functioning of the firearm after such installation. SIG SAUER IS NOT RESPONSIBLE FOR THE FUNCTIONING OF ANY FIREARM IN WHICH REPLACEMENT PARTS ARE INSTALLED BY OTHERS.

11.2 SERVICE POLICY

If you have questions concerning the performance or servicing of your firearm, please write or call:

SIG SAUER, Inc.
Attention: Customer Service
18 Industrial Drive, Exeter, NH 03833
Phone: (603) 610-3000 ext. 1
Fax: (603) 766-7002

IF YOU DO NOT UNDERSTAND THE INSTRUCTIONS FOR OPERATING YOUR PISTOL, IT IS YOUR RESPONSIBILITY TO CALL OUR CUSTOMER SERVICE DEPARTMENT AT (603) 610-3000 EXT. 1 BEFORE USING YOUR FIREARM.



11.3 SHIPPING FIREARMS FOR REPAIR



WARNING

DO NOT SHIP AMMUNITION



In the event you need to return your firearm to the SIG SAUER Service Department, here's what to do:

1. First contact Customer Service at (603) 610-3000 ext. 1 for an RMA number, which will allow SIG SAUER to track the status of your return from its receipt at SIG SAUER through its return to you. Please do not send your firearm until you obtain an RMA number.
2. Make sure that the chamber and magazine(s) are unloaded and that no ammunition is included with your returned firearm.
3. Package the firearm securely to prevent damage. Enclose a letter that includes your name, street address, daytime phone number, model and serial number, and a detailed description of the problem you have experienced or the work you want performed. With the exception of extra magazines, do not include any other accessories such as scopes or mounts.
4. Generally, an individual may ship firearms to the manufacturer for repair or service. Some states and localities, however, prohibit this. If you live in such an area, the firearms must be shipped by and returned to a federally licensed firearms dealer.

11.3 SHIPPING FIREARMS FOR REPAIR (CONTINUED)

5. Federal law prohibits persons who do not possess a Federal Firearms License from shipping a firearm via the U.S. Postal Service. (Note: any shipment of firearms outside U.S. borders is subject to the export laws of the United States and to the valid laws of the specific country, which you must strictly follow; prior to exporting any firearm you should seek legal counsel.)
6. SIG SAUER is not responsible for any firearm until it is received, nor for damage incurred during shipment.
7. Ship your firearms insured and prepaid (we do not accept collect shipments) to:

SIG SAUER, Inc.
Attention: Service Department
18 Industrial Drive Exeter, NH 03833

Don't forget to write your RMA number on the package.

A copy of this instruction manual should always accompany this pistol and be transferred with it upon change of ownership.



12.0 STANDARD SLIDE PARTS DIAGRAM

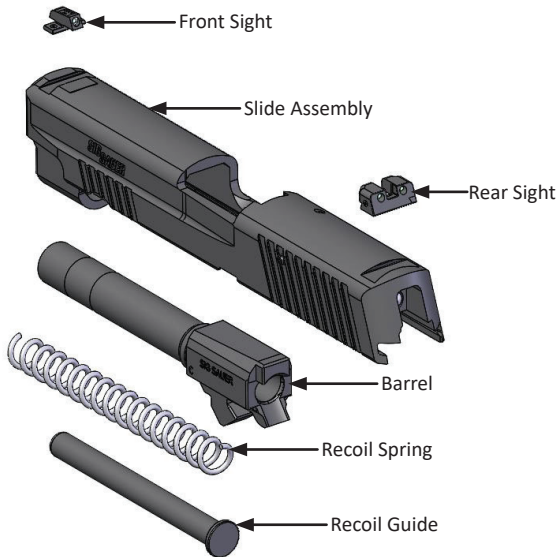

12.1 ROMEO 1 SLIDE PARTS DIAGRAM





12.2 DA/SA FRAME WITH E2 GRIP

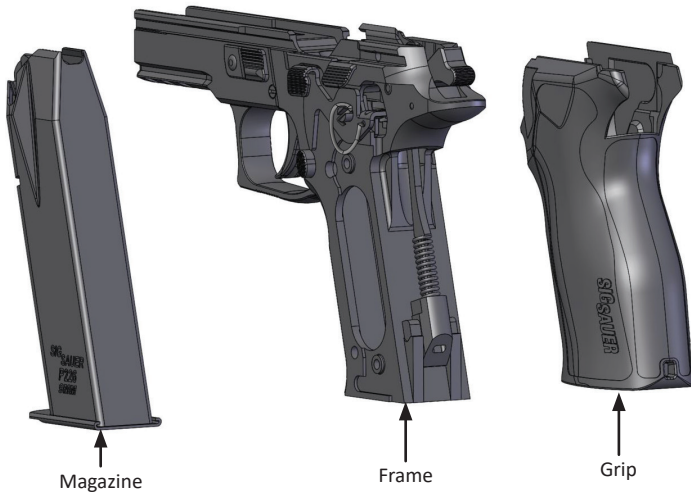

12.3 DAO/DAK FRAME WITH TWO PIECE GRIPS

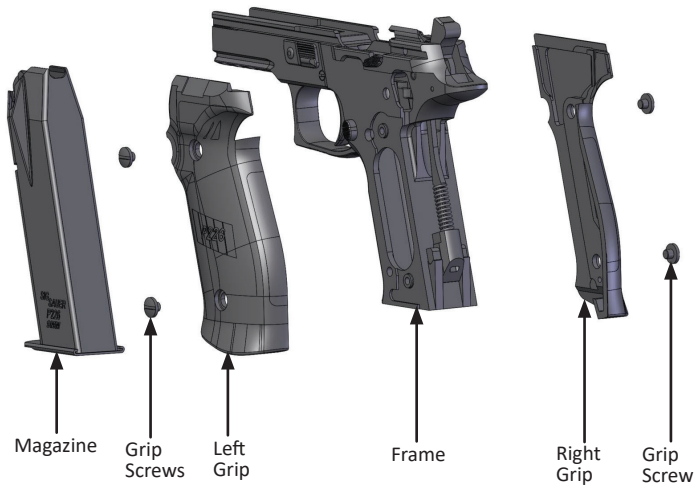



12.4 SAO FRAME WITH TWO PIECE GRIP

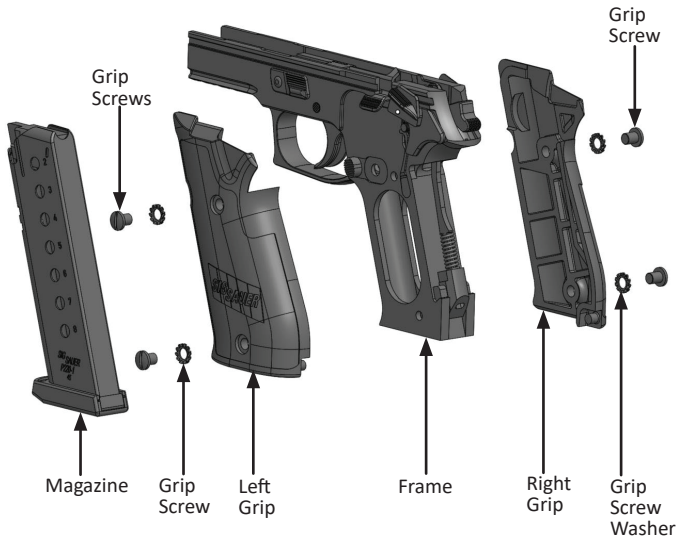

12.5 P229, P226 AND P220 COMPARISON



P226



P229



P220



13.0 TECHNICAL SPECIFICATIONS

The Following Information applies to all Sig classic Line models.¹

- Traditional hammer fired system, available in DA/SA and SAO trigger actions.
- Left hand or right hand operation (magazine catch repositions to either side, SAO versions have an ambidextrous manual safety).
- All metal frame with integral accessory rail.
- Three trigger styles (standard curved, straight and adjustable).
- Solid high-strength stainless steel slide with front and rear cocking serrations.
- High-contrast or SIGLITE® Night Sights in different heights.
- X-Ray Night Sights, adjustable sights available with select models.

13.1 SPECIFICATIONS BY MODEL

Specification tables for each Classic line model are available on-line at, sigsauer.com.

¹ Specifications are approximate and subject to change without notice.

APPENDIX A: SRT SUPPLEMENTAL INSTRUCTIONS

Earlier model Classic Line Pistols (especially P220) were equipped with a SRT safety lever that requires the following procedure for disassembly:

1. Pull back the slide slightly to disengage the slide catch lever. Hold the slide firmly and allow it to move forward slowly.
2. As the slide reaches its closed position, decock the pistol. This will allow the SRT safety lever to completely retract so the slide can be fully removed from the frame.
3. Now slip the complete assembly (comprised of slide, barrel, recoil spring and guide rod) forward and off the frame.
4. Should you need any further support in disassembling your SRT equipped pistol, please call our Customer Service Department at (603) 610-3000 ext 3.



SIG SAUER® LIMITED LIFETIME FIREARMS WARRANTY

SIG SAUER® warrants that the enclosed firearm was originally manufactured free of defects in material, workmanship and mechanical function. For the lifetime of the original purchaser, SIG SAUER agrees to correct any defect in the firearm for the original purchaser by repair, adjustment or replacement, at SIG SAUER's option, with the same or comparable quality components (or by replacing the firearms at SIG SAUER's option); provided, however, that the firearm is returned unloaded and freight prepaid to:

SIG SAUER
18 Industrial Drive
Exeter, NH 03833

This limited warranty is null and void if the firearm has been misused, damaged (by accident or otherwise), fired with hand loaded, reloaded or improper ammunition, fired with an obstruction in the barrel, damaged through failure to provide reasonable and necessary maintenance as described in the manual accompanying the firearm, or if unauthorized repair or any alteration, including of a cosmetic nature, has been performed on the firearm. This limited warranty does not apply to normal wear and tear of any parts. Subject to the foregoing, this limited warranty confers the right to have the covered firearm or its parts repaired, adjusted or replaced exclusively upon the original purchaser, which right is not transferable to any other person. No implied warranties of any kind are made herein and this warranty does not apply to any accessory items attached or appurtenant to the firearm. In no event shall SIG SAUER be liable for any incidental or consequential damages arising from or in connection with this limited warranty.

Notes:



sigsauer.com

FOR PRODUCT SERVICE ON THIS MODEL PLEASE CALL

(603) 610-3000 EXT. 1

72 Pease Boulevard, Newington, NH 03801 USA

All trademarks, service marks, trade names, trade dress, product names and logos appearing in this manual are the property of their respective owners. No trademark or service mark appearing in this manual may be used without written consent of the mark's owner.